



**size matters.  
performance, too™**

# T5 *diminutive asymmetric wall lighting ... sweet!*

... for corridors and perimeters ... low profile Style F144 lights the *entire* wall evenly ... a cost saving alternative to the slot (without amplifying surface imperfections) ... also ideal for art walls, marker and chalk boards, displays and signage in offices, schools and stores.



- classic elliptical housing in matte white ... gray radial baffle
- dimming and quick connect wiring options
- stems, cables and cantilevers available
- optional blanking cover to interrupt light at doorways and intersections on continuous runs
- 2-way and 3-way styles available for lighting both sides of corridor, library stacks, grocery aisles, warehouse stores

GLASS EYE GROUP, BRIAN KELLY

Patents pending, U. S. and foreign



A division of Sylvan R. Shemitz Designs, Inc.  
203.931.4455  
[www.elliptipar.com](http://www.elliptipar.com)

# Style 144 Xtra small enclosed semi-elliptical, one-way

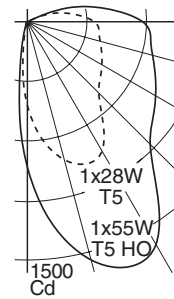
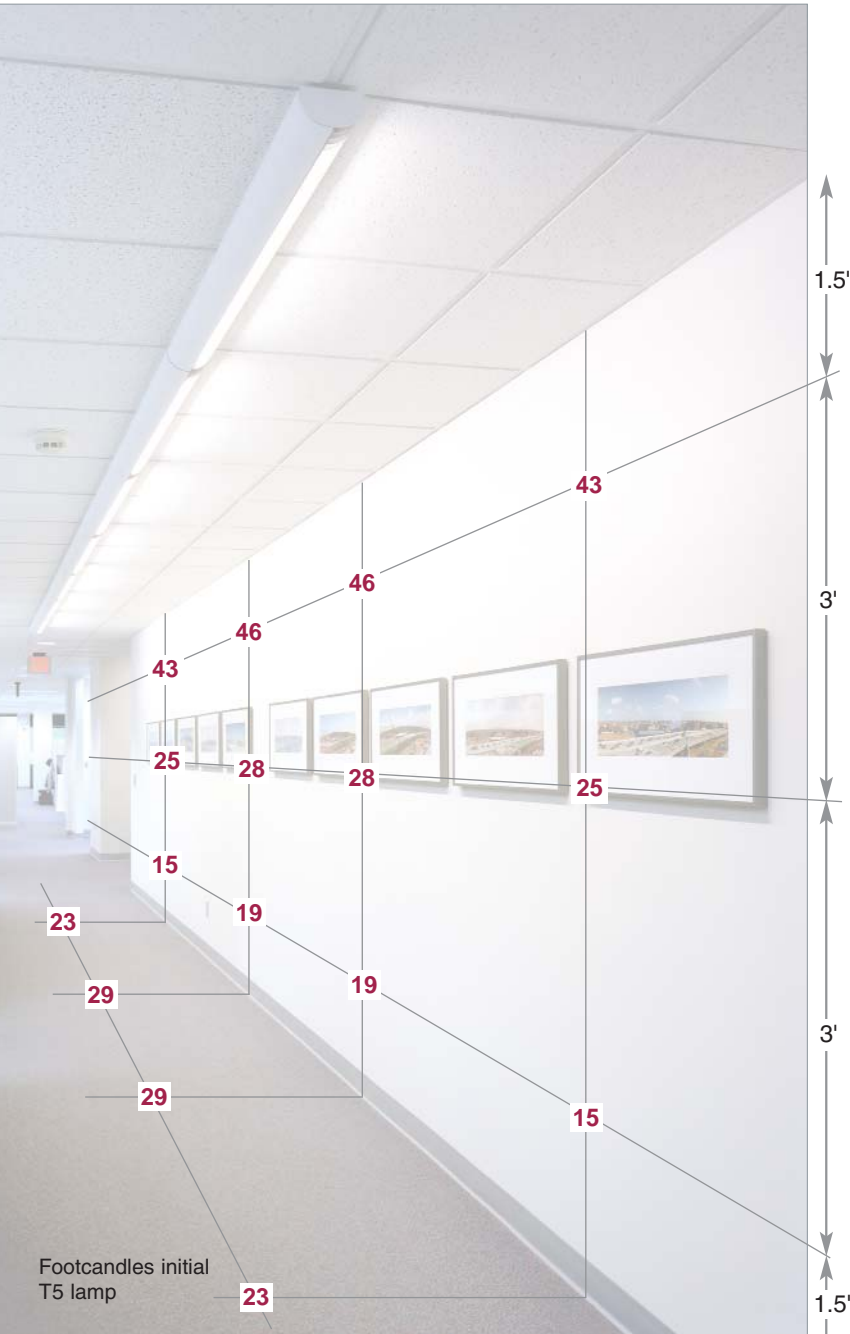

precise reflector engineered to maximize performance of the T5/T5HO lamp

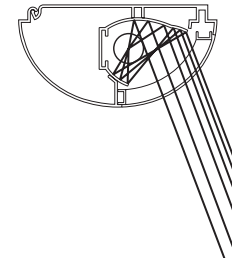

adjustable - max. Cd shown aimed 25° above nadir.

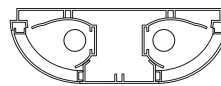
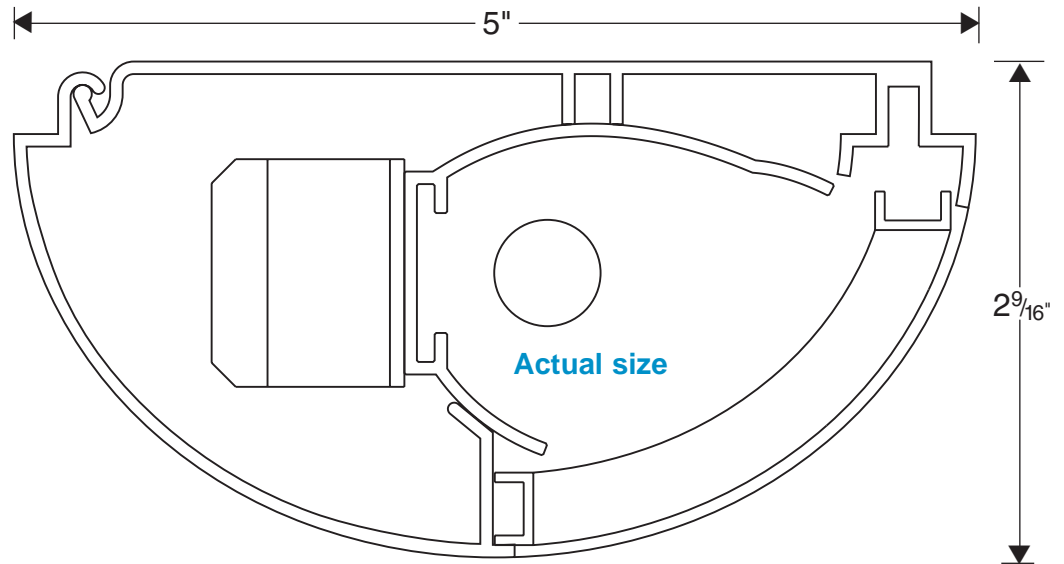

**Style 145**  
two-way

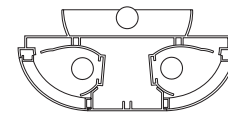

**Style 146**  
three-way with uplight



**elliptipar**  
... there is no equal™

A division of Sylvan R. Shemitz Designs, Inc.  
203.931.4455  
[www.elliptipar.com](http://www.elliptipar.com)

Footcandles initial T5 lamp