

S099

Small Surface Mount LED with Remote Driver

WARNING - RISK OF FIRE AND ELECTRIC SHOCK. THIS PRODUCT TO BE INSTALLED BY A QUALIFIED ELECTRICIAN ONLY.

CAUTION - BE SURE POWER IS DISCONNECTED PRIOR TO WIRING.

INSTALL IN ACCORDANCE WITH ALL N.E.C. AND LOCAL ELECTRICAL CODES.

INSTALLATION INSTRUCTIONS

1. INSTALL MOUNTING PLATE TO CEILING SURFACE OR TO RECESSED JUNCTION BOX (BY OTHERS).
2. INSTALL REMOTE DRIVER PER MA-1357.
3. SECURE FIXTURE TO MOUNTING PLATE USING DECORATIVE CAP NUTS.
4. ORIENT AND AIM FIXTURE PER DIAGRAM PROVIDED. ONCE AIMED, TIGHTEN THUMBSCREWS ON THE FIXTURE BRACKET TO LOCK AIMING POSITION.

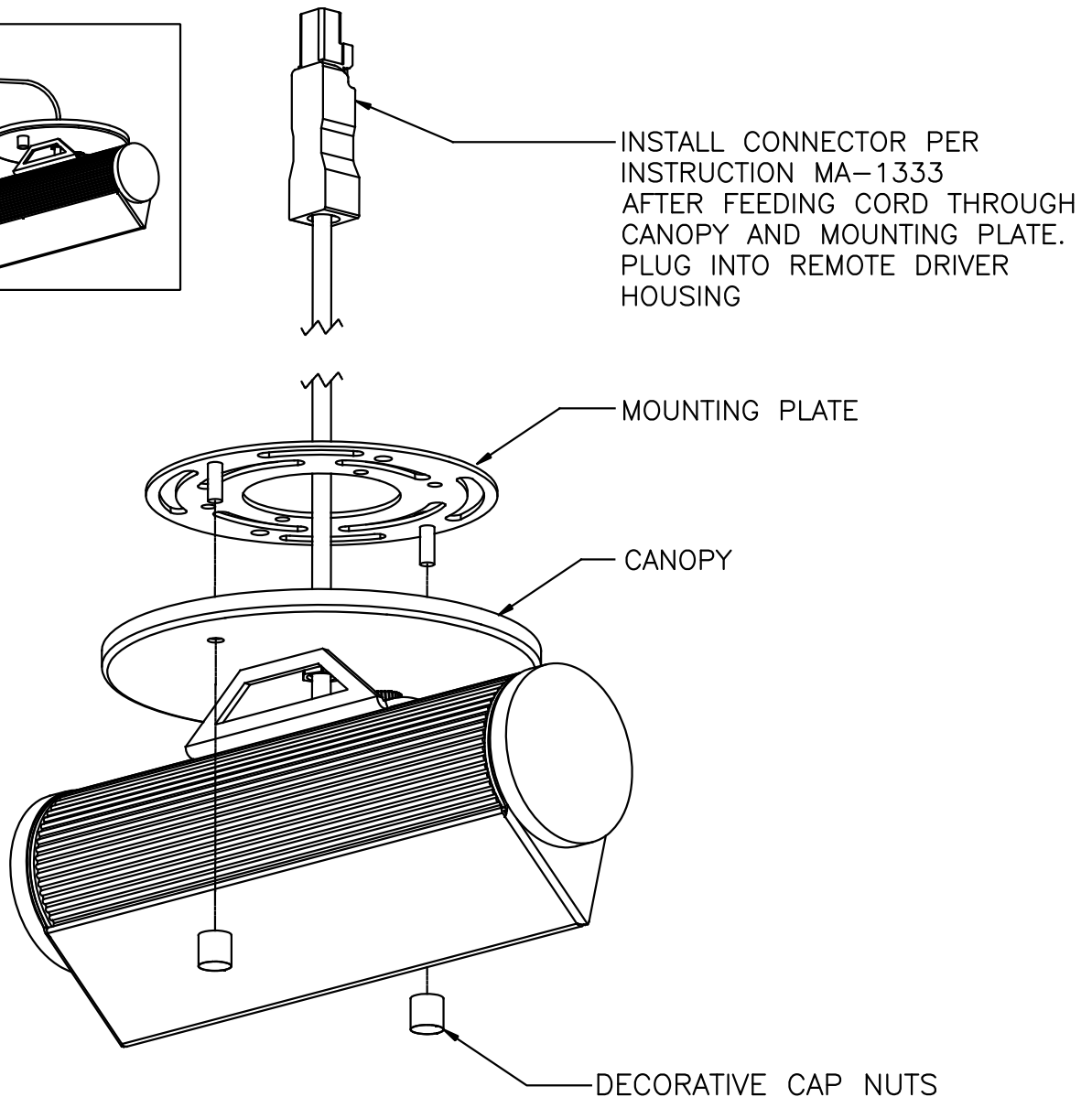
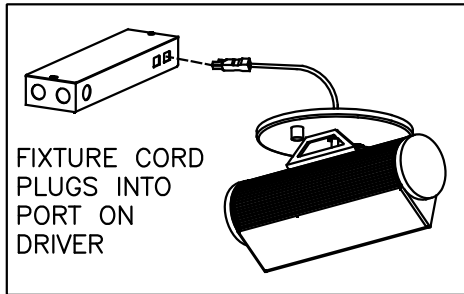

MA-1271 D

CONFIDENTIAL PROPRIETARY INFORMATION
THE INFORMATION HEREIN IS OF A PROPRIETARY NATURE AND IS SUBMITTED IN CONFIDENCE FOR USE BY OUR CLIENTS, CUSTOMERS OR VENDORS ONLY. UNAUTHORIZED REPRODUCTION, PUBLICATION, DISTRIBUTION OR DISSEMINATION, IN WHOLE OR IN PART, IS EXPRESSLY PROHIBITED. THE INFORMATION CONTAINED HEREIN IS AND REMAINS THE PROPERTY OF THE LIGHTING QUOTIENT AND RECEIPT OR POSSESSION OF THIS INFORMATION CONFERS NO RIGHT IN OR LICENSE TO OR TO DISCLOSE TO OTHERS THE SUBJECT MATTER CONTAINED HEREIN FOR ANY BUT AUTHORIZED PURPOSES. ALL RIGHTS RESERVED.